

Torque-Arm Straight-Bore and Tapered-Bushed Speed Reducers

Parts Replacement Manual

TXT/HXT 309A - 315A - 325A, TXT/HXT 409A - 415A - 425A
 TXT/HXT 509B - 515B - 525B, TXT/HXT 609 - 615 - 625

These instructions must be read thoroughly before installation or operation. This instruction manual was accurate at the time of printing. Please see dodgeindustrial.com for updated instruction manuals.

WARNING: To ensure the drive is not unexpectedly started, turn off and lock-out or tag power source before proceeding. Failure to observe these precautions could result in bodily injury.

WARNING: All products over 25 kg (55 lbs) are noted on the shipping package. Proper lifting practices are required for these products.

INSTALLATION

1. Use eyebolts or lifting lugs to lift reducer.
2. Determine the running positions of the reducer (see Figure 1). Note that the reducer is supplied with either four or six plugs: four around the sides for horizontal installations and one on each face for vertical installations. These plugs must be arranged relative to the running positions as follows.

Horizontal Installations: Install the magnetic drain plug in the hole closest to the bottom of the reducer. Throw away the tape that covers the filter/ventilation plug in shipment and install plug in topmost hole. Of the three remaining plugs on the sides of the reducer, the lowest one is the minimum oil level plug.

Vertical Installations: Install the filter/ventilation plug in the hole provided in the top face of the reducer housing. Use the hole in the bottom face for the magnetic drain plug. Of the five remaining holes on the sides of the reducer, use a plug in the upper housing half for the minimum oil level plug.

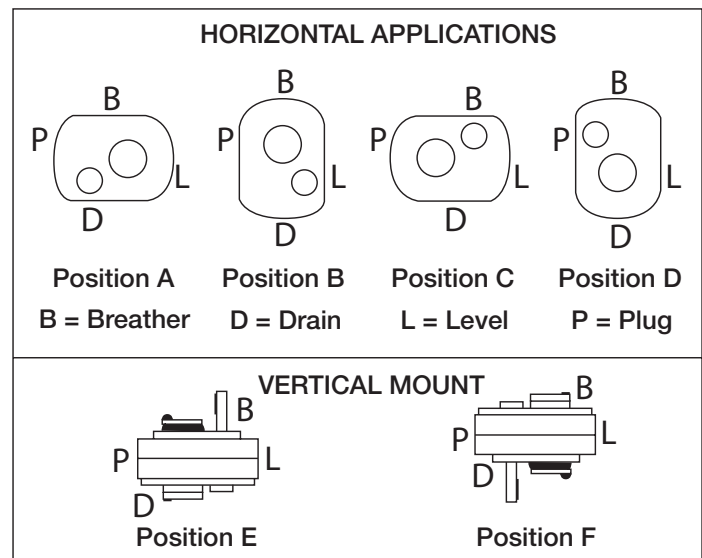

NOTE: Below 15 RPM output speed, oil level must be adjusted to reach the highest oil level plug (P).

Figure 1 - Mounting Positions

The running position of the reducer in a horizontal application is not limited to the four positions shown in Figure 1.

However, if running position is over 20° in position B and D or over 5° in position A and C—either way from sketches—the oil level plug cannot be used safely to check the oil level, unless during the checking, the torque-arm is disconnected and the reducer is swung to within 20° for position A and C or within 5° for position B and D of the positions shown in Figure 1. Because of the many possible positions of the reducer, it may be necessary or desirable to make special adaptations using the lubrication-filling holes furnished along with other standard pipe fittings, stand pipes, and oil level gauges as required.

WARNING: Because of the possible danger to person(s) or property from accidents which may result from the improper use of products, it is important that correct procedures be followed. Products must be used in accordance with the engineering information specified in the catalog. Proper installation, maintenance and operation procedures must be observed. The instructions in the instruction manuals must be followed. Inspections should be made as necessary to assure safe operation under prevailing conditions. Proper guards and other suitable safety devices or procedures as may be desirable or as may be specified in safety codes should be provided, and are neither provided by Dodge® nor are the responsibility of Dodge. This unit and its associated equipment must be installed, adjusted and maintained by qualified personnel who are familiar with the construction and operation of all equipment in the system and the potential hazards involved. When risk to persons or property may be involved, a holding device must be an integral part of the driven equipment beyond the speed reducer output shaft.

3. Mount reducer on driven shaft as follows:

Straight-Bore: Mount reducer on driven shaft as close to bearing as practical. If bushings are used, assemble bushings in reducer first. A set of bushings for one reducer consists of one keyseated bushing and one plain bushing. Extra length set screws are furnished with the reducer. Driven shaft should extend through full length of speed reducer. Tighten both set screws in each collar.

Tapered-Bushed: Mount reducer on driven shaft per instruction sheet packed with tapered bushings.

4. Install sheave on input shaft as close to reducer as practical (see Figure 2).
5. Install motor and v-belt drive so belt will approximately be at right angles to the center line between driven and input shaft (see Figure 3). This will permit tightening the v-belt with the torque-arm.
6. Install torque-arm and adapter plates using the long reducer bolts. The bolts may be shifted to any of the holes on the input end of the reducer.
7. Install torque-arm fulcrum on a flat and rigid support so that the torque-arm will be approximately at right angles to the center line through the driven shaft and the torque-arm anchor screw (see Figure 4). Make sure that there is sufficient take-up in the turnbuckle for belt tension adjustment when using V-belt drive.

CAUTION: Unit is shipped without oil. Add proper amount of recommended lubricant before operating. Failure to observe this precaution could result in damage to or destruction of the equipment.

8. Fill gear reducer with recommended lubricant. See Table 1.

LUBRICATION

NOTICE: Because reducer is shipped without oil, it is necessary to add the proper amount of oil before running. Use a high-grade petroleum-base rust and oxidation inhibited (R&O) gear oil—see tables. Follow instructions on reducer warning tags and in the installation manual.

Under average industrial operating conditions, the lubricant should be changed every 2,500 hours of operating or every six months, whichever occurs first. Drain reducer and flush with kerosene, clean magnetic drain plug, and refill to proper level with new lubricant.

CAUTION: Extreme pressure (EP) lubricants are not recommended for average operating conditions. Failure to observe these precautions could result in bodily injury.

CAUTION: Too much oil will cause overheating and too little will result in gear failure. Check oil level regularly. Failure to observe this precaution could result in bodily injury.

Under extreme operating conditions, such as rapid rise and fall of temperature, dust, dirt, chemical particles, chemical fumes, or oil sump temperatures above 200°F, the oil should be changed every one to three months, depending on severity of conditions.

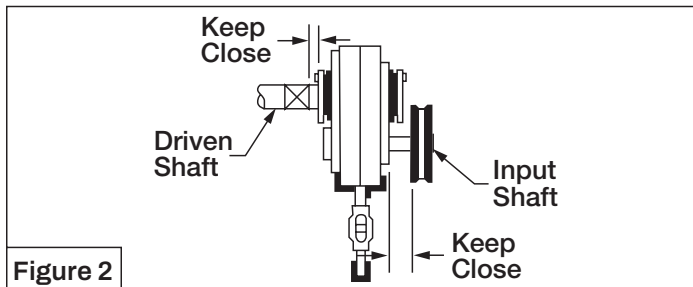

Figure 2

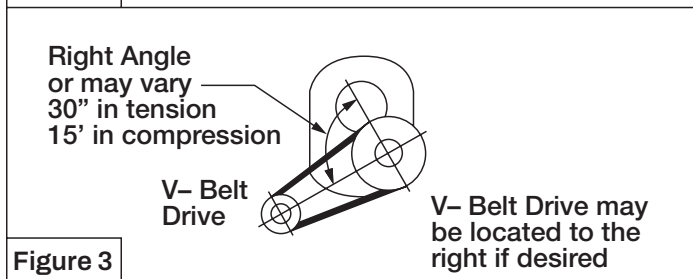

Figure 3

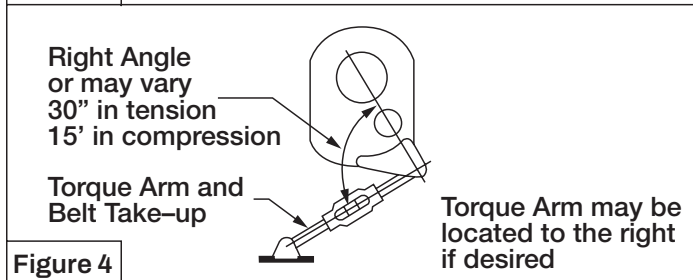

Figure 4

Table 1–Oil Volumes ①

Reducer Sizes TXT/HXT	Approximate Volume of Oil Required to Fill Reducer to Oil Level Plug																	
	② Position A			② Position B			② Position C			② Position D			② Position E			② Position F		
	Oz	③ Qt	L	Oz	③ Qt	L	Oz	③ Qt	L	Oz	③ Qt	L	Oz	③ Qt	L	Oz	③ Qt	L
305A	28	.88	.83	48	1.50	1.42	44	1.38	1.30	44	1.38	1.30	80	2.50	2.37	100	3.13	2.96
309A 315A 325A	48	1.50	1.42	48	1.50	1.42	24	.75	.71	72	2.25	2.13	84	2.63	2.48	96	3	2.84
405A	48	1.50	1.42	72	2.25	2.13	68	2.13	2.01	60	1.88	1.77	128	4	3.79	166	4.88	4.62
409A 415A 425A	60	1.88	1.77	72	2.25	2.13	40	1.25	1.18	56	1.75	1.66	108	3.38	3.19	136	4.25	4.02
505A	108	3.38	3.19	136	4.25	4.02	124	3.88	3.67	120	3.75	3.54	248	7.75	7.33	288	9	8.52
509B 515B 525B	104	3.25	3.08	128	4	3.79	104	3.25	3.08	128	4	3.79	224	7	6.62	272	8.50	8.04
605	144	4.50	4.3	184	5.75	5.4	144	4.50	4.3	160	5	4.7	384	12	11.4	352	11	10.4
609 615 625	136	4.25	4.0	160	5	4.7	136	4.25	4.0	160	5	4.7	276	8.63	8.2	292	9.13	8.6
705	240	7.50	7.1	288	9	8.5	240	7.50	7.1	296	9.25	8.8	608	19	18	552	17.25	16.3
709 715 725	208	6.50	6.1	256	8	7.6	232	7.25	6.9	296	9.25	8.7	492	15.38	14.6	524	16.38	15.5

Notes:

① Consult Dodge for proper oil level for reducers with backstops and which are mounted in C-position or D-position.

② Refer to Figure 1 for mounting positions.

③ U.S. Measure: 1 quart = 32 fluid ounces = .94646 liters.

Table 2 – Oil Recommendations

ISO Grades for Average Operating Conditions	
Ambient Temperatures of 15°F–60°F	
Output RPM	Reducer Size
TXT3A–7 HXT3A–7	TXT305A–705 HXT305A–505A
301–400	220
201–300	220
151–200	220
126–150	220
101–125	220
81–100	220
41–80	220
11–40	220
1–10	220

Ambient Temperatures of 50°F–125°F	
Output RPM	Reducer Size
TXT3A–7 HXT3A–7	TXT305A–705 HXT305A–505A
301–400	320
201–300	320
151–200	320
126–150	320
101–125	320
81–100	320
41–80	320
11–40	320
1–10	320

Notes: If reducer position is to vary from those shown in Figure 1, either more or less oil may be required. Consult product support. If output is less than 15 RPM, consult product support. Below 15 RPM output speed, oil level must be adjusted to reach the highest oil level plug (P).

GUIDELINES FOR LONG-TERM STORAGE

During periods of long storage or when waiting for delivery or installation of other equipment, special care should be taken to protect a gear reducer in order to have it ready and in the best condition when placed into service.

By taking special precautions, problems such as seal leakage and reducer failure due to lack of lubrication, improper lubrication quantity, or contamination can be avoided.

The following precautions will protect gear reducers during periods of extended storage:

Preparation

1. Drain the oil from the unit. Add a vapor phase corrosion inhibiting oil (VCI-105 oil by Daubert Chemical Co.) in accordance with Table 3.
2. Seal the unit airtight. Replace the vent plug with a standard pipe plug and wire the vent to the unit.
3. Cover the shaft extension with a waxy rust preventative compound that will keep oxygen away from the bare metal (Non-Rust X-110 By Daubert Chemical Co.).
4. The instruction manuals and lubrication tags are paper and must be kept dry. Either remove these documents and store them inside or cover the unit with a durable waterproof cover which can keep moisture away.
5. Protect reducer from dust, moisture, and other contaminants by storing the unit in a dry area.
6. In damp environments, the reducer should be packed inside a moisture-proof container or an envelope of polyethylene containing a desiccant material. If the reducer is to be stored outdoors, cover the entire exterior with a rust preventative.

Placing the Reducer into Service

1. Assemble the vent plug into the proper hole.
2. Clean the shaft extensions with petroleum solvents.
3. Fill the unit to the proper oil level using a recommended lubricant. The VCI oil will not affect the new lubricant.
4. Follow the installation instructions provided in this manual.

Table 3—Quantities of VCI #105 Oil

Size	Quarts or Liters
TXT/HXT 3A–305A	.1
TXT/HXT 4A–405A	.2
TXT/HXT 5B–505A	.3
TXT/HXT6–TXT605	.4
TXT/HXT7–TXT705	.5

Notes:
VCI #105 and #10 are interchangeable.
VCI #105 is more readily available.

MOTOR MOUNTS

The motor mount must be installed on output end of reducer as shown in Figure 5. Remove two or three (as required) housing bolts on output end of reducer. Place the motor mount in position and install the longer housing bolts supplied with the motor mount. Tighten bolts to torque specified in Table 4. Install motor, drive sheave, and driven sheave so that the driven sheave is as close to the reducer housing as practical. Install v-belt and tension with the four adjusting screws provided on the T-A M motor mount. Check all bolts to see that they are securely tightened.

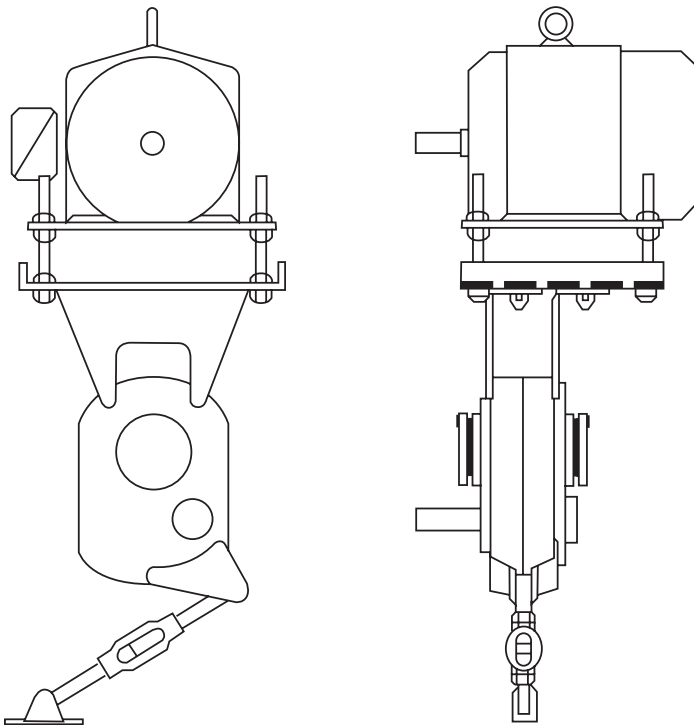

Figure 5 - Motor Mount

WARNING: Belt guard removed for illustration purposes. Do not operate if belt guard is not in place.

REPLACEMENT OF PARTS

NOTICE: Using tools normally found in a maintenance department, a Torque-Arm speed reducer can be disassembled and reassembled by paying careful attention to the following instructions.

Cleanliness is very important to prevent the introduction of dirt into the bearings and other parts of the reducer. A tank of clean solvent, an arbor press, and equipment for heating bearings and gears (for shrinking these parts on shafts) should be available.

The oil seals are of the rubbing type and considerable care should be used during disassembly and reassembly to avoid damage to the surface on which the seals rub.

The keyseat in the input shaft, as well as any sharp edges on the output hub, should be covered with tape or paper before disassembly or reassembly. Also, be careful to remove any burrs or nicks on surfaces of the input shaft or output hub before disassembly or reassembly.

Ordering Parts: When ordering parts for reducer, specify reducer size number, reducer serial number, part name, part number, and quantity.

It is strongly recommended that, when a pinion or gear is replaced, the mating pinion or gear is replaced as well.

If the large gear on the output hub must be replaced, it is recommended that an output hub assembly of a gear assembled on a hub be ordered to secure undamaged surfaces on the output hub where the output seals rub. However, if it is desired to use the old output hub, press the gear and bearing off and examine the rubbing surface under the oil seal carefully for possible scratching or other damage resulting from the pressing operation. To prevent oil leakage at the shaft oil seals, the smooth surface of the output hub must not be damaged.

If any parts must be pressed from a shaft or from the output hub, this should be done before ordering parts to make sure that none of the bearings or other parts are damaged in removal. Do not press against outer race of any bearing. Because old shaft oil seals may be damaged in disassembly, it is advisable to order replacements for these parts.

Removing Reducer from Shaft

CAUTION: Remove all external loads from drive before removing or servicing drive or accessories.

Straight-Bore: Loosen screws in both output hub collars. Remove the collar next to the end of the shaft. This exposes three puller holes in the output hub to permit the use of a wheel puller. In removing the reducer from the shaft, be careful not to damage the ends of the hub.

Tapered-Bushed:

1. Remove bushing screws.
2. Place the screws in the threaded holes provided in the bushing flanges. Tighten the screws alternately and evenly until the bushings are free on the shaft. For ease of tightening screws, make sure screw threads and threaded holes in bushing flanges are clean.
3. Remove the outside bushing, the reducer, and then the inboard bushing.

Disassembly:

1. Position the reducer on its side and remove all housing bolts. Drive dowel pins from housing. Gently tap the output hub and input shaft with a soft hammer (rawhide, not a lead hammer) to separate the housing halves. Open housing evenly to prevent damage to the parts inside.
2. Lift shaft, gear, and bearing assemblies from housing.
3. Remove seals from housing.

Reassembly:

1. Output Hub Assembly: Heat gear to 325°F–350°F to shrink onto hub. Heat bearings to 270°F–290°F to shrink onto hub. Any injury to the hub surfaces where the oil seals rub will cause leakage, making it necessary to use a new hub.
2. Countershaft Assembly: Shaft and pinion are integral. Press gear and bearings on shaft. Press against inner (not outer) race of bearings.
3. Input Shaft Assembly: Shaft and pinion are integral. Press bearings on shaft. Press against inner (not outer) race of bearings.
4. Drive the two dowel pins into place in the right-hand housing half. Apply RTV732 sealant to carriers for right-hand side (backstop side) of reducer. Install carriers and torque bolts per Table 4.
5. Place right-hand housing half on blocks to allow for protruding end of output hub.
6. Install bearing cups in right-hand housing half, making sure they are properly seated.
7. Mesh output hub gear and small countershaft gear together and set in place in housing. Set input shaft assembly in place in the housing. Make sure bearing rollers (cones) are properly seated in their cups. Set bearing cups for left-hand housing half in place on their rollers.
8. Clean housing flange surfaces on both halves, making sure not to nick or scratch flange face. Place a 1/8 inch bead of RTV732 sealant on flange face (make sure RTV is placed between bolt holes and inside of flange face). Place other housing half into position and tap with a soft hammer (rawhide, not lead hammer) until housing bolts can be used to draw housing halves together. Torque housing bolts per torque values listed in Table 4.

9. Place output hub seal carrier in position without shims and install two carrier screws diametrically opposed. Torque each screw to 25 in-lbs. Rotate the output hub to roll in the bearings and then torque each screw to 50 in-lbs. Again, turn output hub to roll in the bearings. With a feeler or taper gage, measure the gap between the housing and the carrier flange. To determine the required shim thickness, take the average of the two feeler gage readings. Remove carrier and install the required shims plus .002 inches. Install carrier with shims and torque bolts per Table 4. Rotate hub assembly, tap lightly with rawhide mallet on end of hub, while rotating, to ensure bearings are seated. Using a dial indicator check end play of hub bearings, endplay should be .001–.003 inches. Repeat this process as necessary to obtain proper end play. Place a 1/8 inch diameter bead of RTV732 sealant inside the carrier at the shim I.D. and install carrier on reducer housing. Torque carrier bolts to value shown in Table 4.
10. Adjust the countershaft bearings using the same method as in step 8 above. The axial end play should be between .001–.003 inches.
11. Again, using the same procedure as in step 8, adjust the input shaft bearings, except the axial end play should be .002–.004 inches.
12. Using gaskets, install input shaft cover and counter shaft cover to right-hand housing half. Install input and output seals. Extreme care should be used when installing seals to avoid damage due to contact with sharp edges on the input shaft or output hub. The possibility of damage and consequent oil leakage can be decreased by covering all sharp edges with tape prior to seal installation. Fill cavity between seal lips with grease. Seals should be pressed or tapped with a soft hammer evenly into place in the carrier, applying pressure only on the outer edge of the seals. A slight oil leakage at the seals may be evident during initial running, but should disappear unless seals have been damaged.
13. Install bushing backup plates and snap rings on tapered-bushed reducers or hub collars on straight-bore reducers.

Table 4–Recommended Torque Values

Reducer Size	Dry Torque (lb–ft)	
	Housing Bolts	Output Hub Seal Carrier Screws
TXT/HXT 305A & 3A	50–45	17–15
TXT/HXT 405A & 4A	50–45	30–27
TXT/HXT 505A & 5B	75–68	30–27
TXT605 & TXT/HXT 6	75–68	30–27
TXT705 & TXT/HXT 7	150–135	50–45

Reducer Size	Dry Torque (lb–ft)	
	C’shaft Bearing Cover Screws	Input Shaft Seal Carrier Screws
TXT/HXT 305A & 3A	17–15	17–15
TXT/HXT 405A & 4A	30–27	30–27
TXT/HXT 505A & 5B	30–27	30–27
TXT605 & TXT/HXT 6	30–27	30–27
TXT705 & TXT/HXT 7	50–45	50–45

Table 5–Manufacturers’ Part Numbers for Replacement Output Hub Bearings

Torque–Arm Reducer Drive Size	Output Bearing
	Dodge Part No.
TXT/HXT 305A	402272 403127
TXT/HXT 309A TXT/HXT 315A TXT/HXT 325A	402272 403127
TXT/HXT 405A	402268 403163
TXT/HXT 409A TXT/HXT 415A TXT/HXT 425A	402268 403163
TXT/HXT 505A	402193 403016
TXT/HXT 509B TXT/HXT 515B TXT/HXT 525B	402193 403016
TXT605	402050 403140
TXT/HXT 609 TXT/HXT 615 TXT/HXT 625	402050 403140
TXT705	402058 403111
TXT/HXT 709 TXT/HXT 715 TXT/HXT 725	402058 403111

Table 6–Manufacturers’ Part Numbers for Replacement Countershaft Bearings

Torque-Arm Reducer Drive Size	Countershaft Bearing Input Side
	Dodge Part No.
TXT/HXT 309A TXT/HXT 315A TXT/HXT 325A	402273 403094
TXT/HXT 409A TXT/HXT 415A TXT/HXT 425A	402000 403000
TXT/HXT 509A TXT/HXT 515A TXT/HXT 525A	402203 403027
TXT/HXT 609 TXT/HXT 615 TXT/HXT 625	402054 403159
TXT/HXT 709 TXT/HXT 715 TXT/HXT 725	402256 403053
TXT/HXT 309A TXT/HXT 315A TXT/HXT 325A	402273 403094
TXT/HXT 409A TXT/HXT 415A TXT/HXT 425A	402000 403000
TXT/HXT 509A TXT/HXT 515A TXT/HXT 525A	402203 403027
TXT/HXT 609 TXT/HXT 615 TXT/HXT 625	402052 403142
TXT/HXT 709 TXT/HXT 715 TXT/HXT 725	402256 403053

Table 7–Manufacturers’ Part Numbers for Replacement Input Bearings

Torque-Arm Reducer Drive Size	Input Bearings Input Side
	Dodge Part No.
TXT/HXT 305A	402190 403132
TXT/HXT 309A TXT/HXT 315A TXT/HXT 325A	402204 403139
TXT/HXT 405A	402179 403006
TXT/HXT 409A TXT/HXT 415A TXT/HXT 425A	402280 403027
TXT/HXT 505A	402270 403026
TXT/HXT 509B TXT/HXT 515B TXT/HXT 525B	402144 403104
TXT605	402053 403106
TXT/HXT 609 TXT/HXT 615 TXT/HXT 625	402196 403091
TXT705	402057 403143
TXT/HXT 709 TXT/HXT 715 TXT/HXT 725	402150 403106
TXT/HXT 305A	402271 403101
TXT/HXT 309A TXT/HXT 315A TXT/HXT 325A	402273 403094
TXT/HXT 405A	402285 403125
TXT/HXT 409A TXT/HXT 415A TXT/HXT 425A	402142 403102
TXT/HXT 505A	402266 403073
TXT/HXT 509B TXT/HXT 515B TXT/HXT 525B	402266 403073
TXT605	402123 403009
TXT/HXT 609 TXT/HXT 615 TXT/HXT 625	402197 403091
TXT705	402078 403034
TXT/HXT 709 TXT/HXT 715 TXT/HXT 725	402088 403047

Parts for TXT/HXT 3A, 4A and 5B Straight-Bore and Tapered-Bushed Speed Reducers

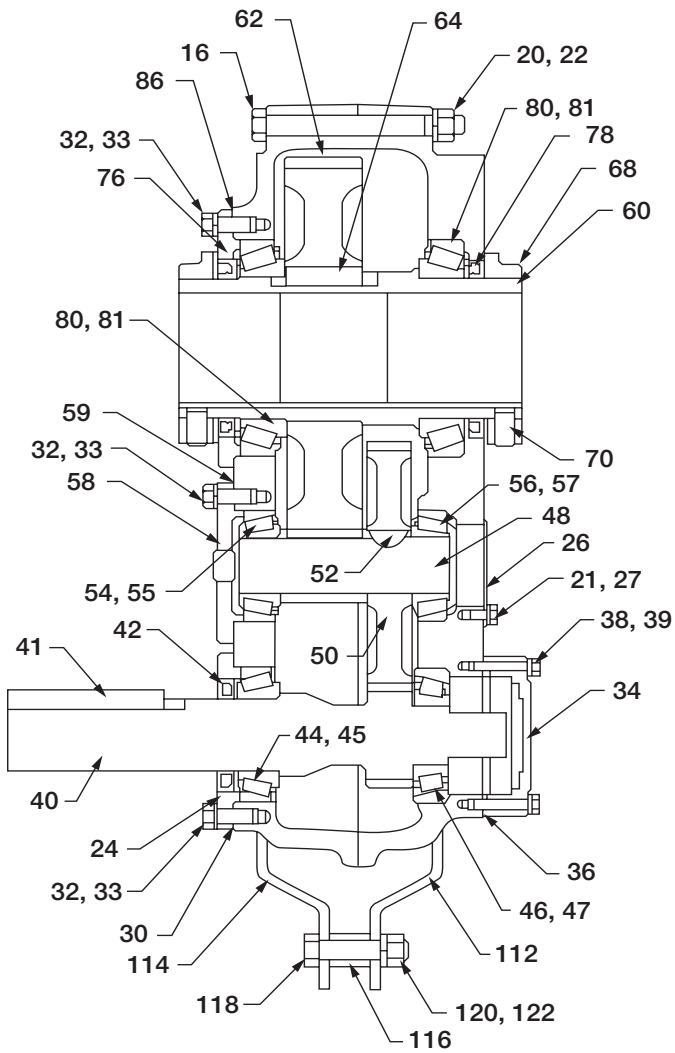

STRAIGHT BORE

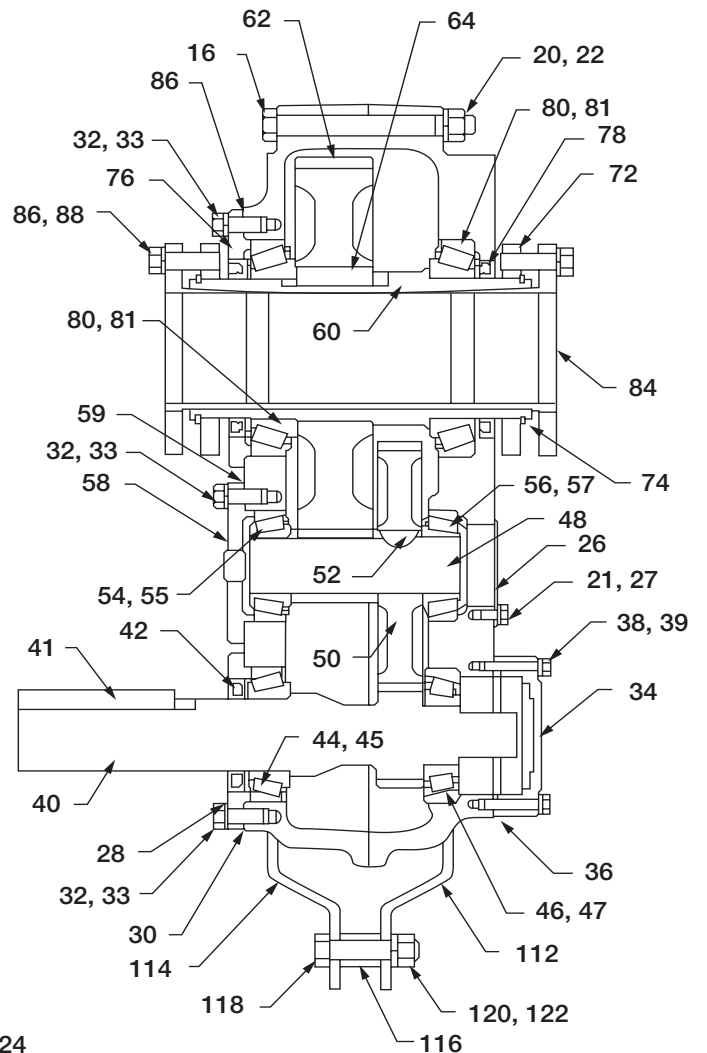

TAPER BUSHED

Note: The two digit numbers are for reference only. Order parts by the six digit number in the parts list. Each six digit number is a complete identification of the part or assembly.

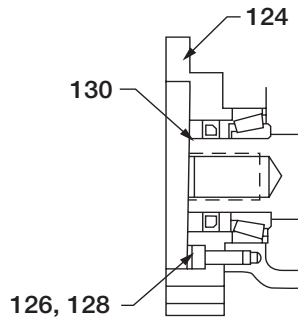

HYDROIL INPUT

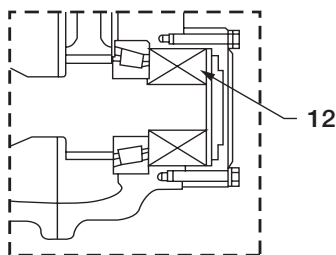

BACKSTOP ASSEMBLY

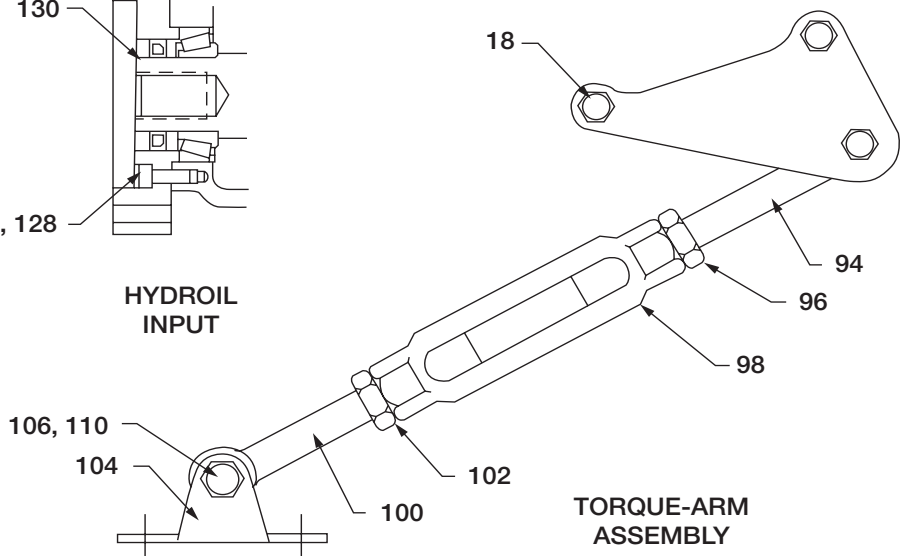

TORQUE-ARM ASSEMBLY

**Parts for TXT/HXT 3A, 4A and 5B
Straight-Bore and Tapered-Bushed Speed Reducers**

Ref.	Name of Part	No. Req'd	TXT3A HXT3A	TXT4A HXT4A	TXT5B HXT5B	
12	Backstop Assembly	1	243106	244106	245154	
①	Housing ②	1	900287	900287	904287	
①	Air Vent	1	241237	241237	245237	
16	Housing Bolt	6	411440	411442	411464	
18	Adapter Housing Bolt	2	411442	411444	411466	
19	Washer ③	4	419094	419094	419096	
20	Lock Washer	6	419012	419012	419013	
22	Hex Nut	8	407089	407089	407091	
24	Dowel Pin	2	420055	420055	420110	
①	Pipe Plug	2	430031	430031	430033	
①	Magnetic Plug	1	433060	430060	430062	
26	Counter Shaft Bearing Cover (Backstop Side)	1	243559	244574	244574	
21	Countershaft Cover Screw	4	416524	411034	411394	
27	Lock Washer	4	419007	419009	419009	
28	Input Shaft Seal Carrier	1	243543	244577KIT	245597KIT	
30 ⑥	Input Shaft Shim Pack	2	389704	389711	389732	
32	Carrier / Cover Screws	⑦	411390	411407	411407	
33	Lock Washer	⑦	419010	419011	419011	
34	Backstop Cover	1	243560	244493	245547	
38	Backstop Cover Screw	4	416524	411035	411406	
39	Lock Washer	4	419007	419009	419009	
40	Input Shaft with Pinion	9:1 Ratio	1	243549	244579	245599
		15:1 Ratio	1	243550	244580	245600
		25:1 Ratio	1	243551	244581	245601
41	Input Shaft Key	1	443032	443082	443113	
	Countershaft Assembly ②	9:1 Ratio	1	389729	389730	389731
		15:1 Ratio	1	389700	389707	389714
		25:1 Ratio	1	389701	389708	389715
48	Countershaft with Pinion ③	1	243555	244590	245596	
50 ⑥	First Reduction Gear ③	9:1 Ratio	1	243327	244482	245482
		15:1 Ratio	1	243238	244214	245214
		25:1 Ratio	1	243239	244212	245212
52 ③	Standard Gear Key	1	D8242	D8243	D8243	
⑧ ⑩	Crescent Gear Key	1	243215KIT	244215KIT	244215KIT	
58	Countershaft Bearing Cover (Input Shaft)	1	243545KIT	244578KIT	245594KIT	
59	Countershaft Bearing Shim Pack	2	389705	389712	389718	
	Output Hub Assembly ② ⑧	Straight	1	389702	389709	389716
		Tapered	1	389703	389710	389717
60 ⑥	Output Hub ③	Straight	1	243557	244589	245591
		Tapered	1	243556	244588	245590
62 ⑥	Output Gear ③	1	243570	244188	245186	
64 ⑥	Output Gear Key ③	1	389733	391015	391026	
80 ⑥	Output Hub Bearing Cone	2	402272	402268	402193	
68	Output Hub Collar	2	243572	244658	245598	
70	Collar Screw	4	400098	400150	400154	
68	Output Hub Collar	2	243572	244658	245598	
70	Collar Screw	4	400098	400150	400154	
72	Bushing Backup Plate ⑥	2	243308	244099	024114	
74	Retaining Ring ⑥	2	421109	421108	421107	
76	Output Hub Seal Carrier (Input Side)	1	243547	244591	245592	
	Output Hub Bearing Kit ②	1	389589	389592	389596	
82 ⑥	Output Hub Bearing Shim Pack	2	389706	389713	389719	
	Seal Kit ②	1	389720	389721	389722	
36 ⑥	Backstop Cover Gasket ③	1	243561	244593	245220	
42 ⑥	Input Shaft Seal ③	1	A73106	A73108	334277	
78 ⑥	Output Hub Seal ③	2	902286	A73109	904286	
①	RTV Sealant Tube	1	415112-80-H			

**Parts for TXT/HXT 3A, 4A and 5B
Straight-Bore and Tapered-Bushed Speed Reducers**

Ref.	Name of Part	No. Req'd	TXT3A HXT3A	TXT4A HXT4A	TXT5B HXT5B	
30 59 82 ⑨	Complete Shim Kit	1	243139	244153	245139	
②	Complete Bearing Kit	1	392345	392347	392350	
③	Input Bearing Kit ②	1	389587	389590	389594	
44 ⑧	Input Shaft Bearing ③	Cone	1	402204	402280	402144
45 ⑧	(Input Side) ③					
46 ⑧	Input Shaft Bearing ③	Cone	1	402273	402142	402266
47 ⑧	(Backstop Side) ③					
③	Countershaft Bearing Kit ②	1	389588	389591	389595	
54 ⑧	Countershaft Bearing ③	Cone	1	402273	402000	402203
55 ⑧	(Input Side) ③					
56 ⑧	Countershaft Bearing ③	Cone	1	402273	402000	402203
57 ⑧	(Backstop Side) ③					
②	Output Hub Bearing Kit ③	1	389589	389592	389596	
80 ⑧	Output Hub ③	Cone	2	402272	402268	402196
81 ⑧	Bearing ③					
84	Bushing Assembly ②	1-5/16" Bore	1	243282	-----	-----
		1-3/8" Bore	1	243284	-----	-----
		1-7/16" Bore	1	243260	244079	-----
		1-1/2" Bore	1	243262	244081	-----
		1-5/8" Bore	1	243264	244083	-----
		1-11/16" Bore	1	243268	244085	-----
		1-3/4" Bore	1	243266	244087	-----
		1-7/8" Bore	1	243270	244089	245084
		1-15/16" Bore	1	243272	244093	245086
		2" Bore	1	243274	244095	245088
		2-1/8" Bore	1	-----	244109	-----
		2-3/16" Bore	1	243276	244111	245090
		2-1/4" Bore	1	-----	244113	245092
		2-7/16" Bore	1	-----	244115	245094
		2-1/2" Bore	1	-----	-----	245099
2-11/16" Bore	1	-----	-----	245110		
2-15/16" Bore	1	-----	-----	245112		
86	Bushing Screw ③	6	03201 8008CJ	032018 010CJ	411435	
88	Lock Washer ③	6	419011	419011	419012	
90	Key, Bushing to Shaft ③	1-5/16" Bore	1	443264	-----	-----
		1-3/8" Bore	1	443264	-----	-----
		1-7/16" Bore	1	443265	445254	-----
		1-1/2" Bore	1	443265	443254	-----
		1-5/8" Bore	1	443265	443254	-----
		1-11/16" Bore	1	443266	443254	-----
		1-3/4" Bore	1	443266	443254	-----
		1-7/8" Bore	1	443267	443255	443251
		1-15/16" Bore	1	443269	443255	443251
		2" Bore	1	443268	443255	443251
		2-1/8" Bore	1	-----	443258	-----
		2-3/16" Bore	1	443270	443259	443251
		2-1/4" Bore	1	-----	446260	443251
		2-7/16" Bore	1	-----	443261	443243
		2-1/2" Bore	1	-----	-----	443244
2-11/16" Bore	1	-----	-----	443245		
2-15/16" Bore	1	-----	-----	443250		
	Key,	1 ③	443262	-----	443202	
①	Bushing to Output Hub ③	2-3/16" to 2-1/2" Bore	1	-----	443257	-----
		2-7/16" to 3" Bore	1	-----	443257	-----

**Parts for TXT/HXT 3A, 4A and 5B
Straight-Bore and Tapered-Bushed Speed Reducers**

Ref.	Name of Part	No. Req'd	TXT3A HXT3A	TXT4A HXT4A	TXT5B HXT5B	
	Torque-Arm Assembly ②	1	243097	245097	245097	
94	Rod End ③ ⑩	1	A73087	A73146	A73146	
96	Hex Nut ③ ⑩	1	407095	A73264	A73264	
98	Turnbuckle ③ ⑩	1	A73089	A73147	A73147	
100	Extension ③ ⑩	1	A73088	A73148	A73148	
102	LH Hex Nut ③ ⑩	1	407244	A73263	A73263	
104	Fulcrum ③	1	243249	246249	246249	
106	Fulcrum Screw ③	1	0320128016EJ			
110	Hex Nut ③	1	407093	407093	407093	
	Adapter Assembly ③	1	259153	259154	259155	
112	RH Adapter Plate ③	1	243242P	244244P	245242P	
114	LH Adapter Plate ③	1	243241P	244243P	245241P	
116	Adapter Bushing ③	1	243243	245243	245243	
118	Adapter Bolt ③	1	411437	244243	411460	
120	Lock Washer ③	1	419012	419013	419013	
122	Hex Nut ③	1	407089	407091	407091	
124	Motor Adapter	15:1 Ratio	1	243539	244572	245606
		25:1 Ratio	1	243541	244572	245607
126	Adapter Screw	⑩	417081	417108	415023	
128	Lock Washer	⑩	419046	419047	-----	
130 ③	Input Shaft with Pinion	15:1 Ratio	1	243553	244583	245603
		25:1 Ratio	1	243554	244585	245604

Notes:

- ① Not shown on drawing
- ② Includes the following part: housing assembly includes a two-piece housing; bushing assembly includes 2 bushings
- ③ Makes up assembly under which it is listed
- ④ Washer is used on housing bolts at dowel pin locations
- ⑤ Straight-Bore only
- ⑥ Tapered-Bushed only
- ⑦ 14 required on TXT3A and TXT4A; 15 required on TXT5B; 10 required on HXT3A, HXT4A and HXT5B.
- ⑧ Recommended spare parts
- ⑨ On size TXT/HXT 3A for 1-15/16" through 1-3/4" bores and TXT/HXT 5B for 1-7/16" through 2-1/4" bores.
- ⑩ 4 required on HXT3A and HXT4A ; 5 required on HXT5B
- ⑪ Zinc plated as of 2016
- ⑫ Key was changed from the crescent shaped to standard key in April, 2006. For size 3A units built before April, 2006 use part number 243215. For size 3A units built after April, 2006 use part number D8242. For size 4A and 5B units built before April, 2006 use part number 244215. For size 4A and 5B units built after April, 2006 use part number D8243
- ⑬ Assembly includes output hub bearing cone as of 2018

Parts for TXT/HXT 305A, 405A and 505B Straight-Bore and Tapered-Bushed Speed Reducers

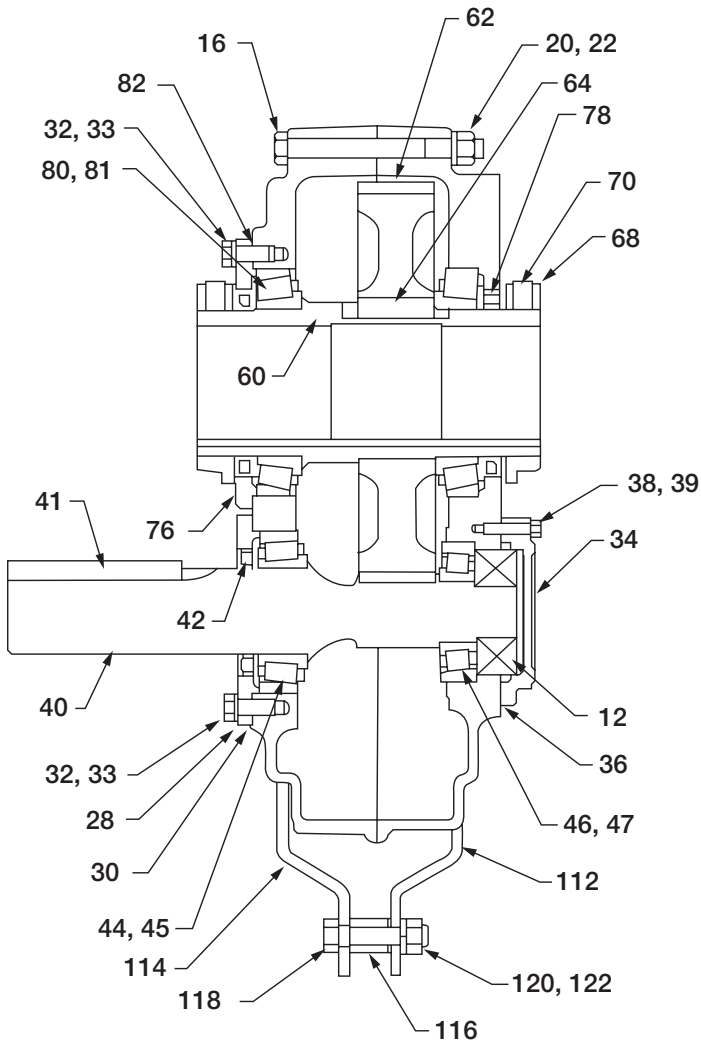

STRAIGHT BORE

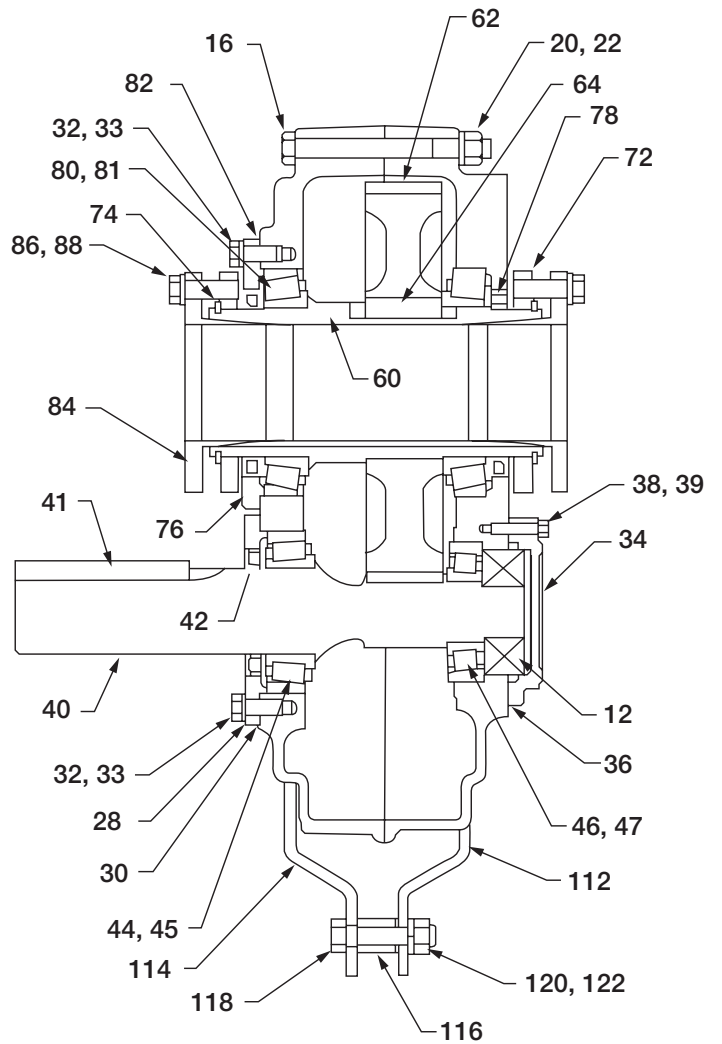

TAPER BUSHED

Note: The two digit numbers are for reference only. Order parts by the six digit number in the parts list. Each six digit number is a complete identification of the part or assembly.

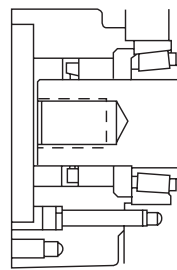

HYDROIL INPUT

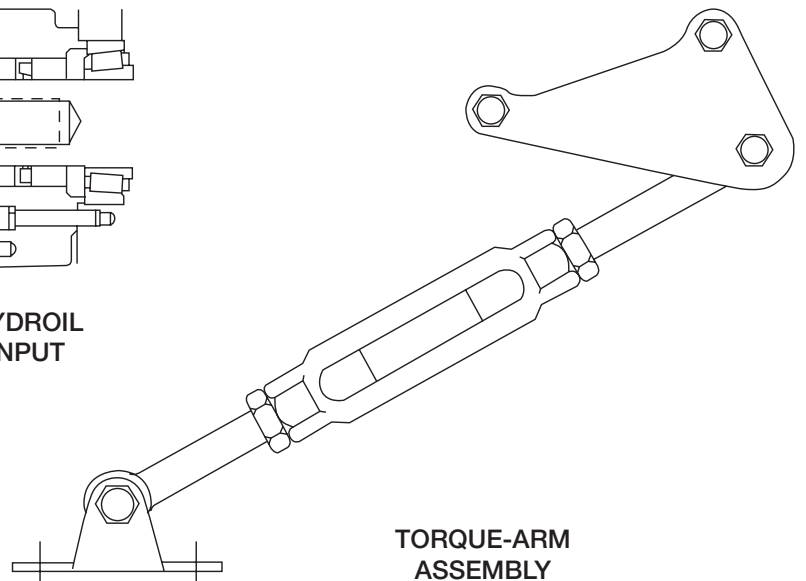

TORQUE-ARM ASSEMBLY

**Parts for TXT/HXT 305A, 405A and 505B
Straight-Bore and Tapered-Bushed Speed Reducers**

Ref.	Name of Part	No. Req'd	TXT305A HXT305A	TXT405A HXT405A	TXT505A HXT505A	
12	Backstop Assembly	1	252101	244148	246101	
①	Housing	1	253165	254218	255216	
①	Air Vent	1	900287	900287	904287	
16	Housing Bolt	6	411440	411442	411464	
18	Adapter Housing Bolt	2	411442	411444	411466	
④	Washer ①	4	419094	419094	419096	
20	Lock Washer	6	419012	419012	419013	
22	Hex Nut	8	407089	407089	407091	
24	Dowel Pin	2	420055	420055	420110	
①	Pipe Plug	2	430031	430031	430033	
①	Magnetic Plug	1	430060	430060	430062	
28	Input Shaft Seal Carrier	1	253177	254224	255224	
30⑥	Input Shaft Shim Pack	2	389723	389724	389725	
32	Carrier / Cover Screws	⑦	411390	411407	411407	
33	Lock Washer	⑦	419010	419011	419011	
34	Backstop Cover	1	253175	254223	255019	
38	Backstop Cover Screw	4	416524	411035	411406	
39	Lock Washer	4	419007	419009	419009	
40⑧	Input Shaft with Pinion	1	253170	254230	255221	
41	Input Shaft Key	1	443078	443096	443113	
	Output Hub Assembly ②	Straight	1	389702HA	389709HA	389716HA
		Tapered	1	389703HA	389710HA	389717HA
60⑧	Output Hub ③	Straight	1	243557	244589	245591
		Tapered	1	243556	244588	245590
62⑧	Output Gear ③	1	243570	244188	245186	
64⑧	Output Gear Key ③	1	389733	391015	391026	
80⑧	Output Hub Bearing Cone ③	1	402272	402268	402193	
68⑤	Output Hub Collar	2	243572	244658	245598	
70⑤	Collar Screw	4	400098	400150	400154	
72	Bushing Backup Plate ⑥	2	243308	244099	245114	
74	Retaining Ring ⑥	2	421109	421108	421107	
76	Output Hub Seal Carrier (Input Side)	1	243547	244591	245592	
82⑧	Output Hub Bearing Shim Pack	2	389706	389713	389719	
	Seal Kit ②	1	389726	389727	389728	
36⑧	Backstop Cover Gasket ③	1	253176	254221	255020	
42⑧	Input Shaft Seal ③	1	351123	334277	245546	
78⑧	Output Hub Seal ③	2	902286	A73109	904286	
①	Gasket Eliminator Tube	1		415115-80-H		
②	Bearing Kit	1	392346	392348	392351	
44③④	Input Shaft Bearing	Cone	1	402190	402179	402270
45③④	Input Side	Cup	1	403132	403006	403026
46③④	Input Shaft Bearing	Cone	1	102271	402285	402266
47③④	Backstop Side	Cup	1	403101	403125	403076
①③	Output Hub Bearing Kit ②	1	389589	389592	389596	
80⑧	Output Bearing Hub ③	Cone	2	402272	402268	402193
81⑧	Output Bearing Hub ③	Cup	2	403127	403163	403016
30 82⑧⑨	Complete Shim Kit	1	240125	240126	240127	
84	Bushing Assembly ②	1-5/16" Bore	1	243282	-----	-----
		1-3/8" Bore	1	243284	-----	-----
		1-7/16" Bore	1	243260	244079	-----
		1-1/2" Bore	1	243262	244081	-----
		1-5/8" Bore	1	243264	244083	-----
		1-11/16" Bore	1	243268	244085	-----
		1-3/4" Bore	1	243266	244087	-----
		1-7/8" Bore	1	243270	244089	245084
		1-15/16" Bore	1	243272	244093	245086
	2" Bore	1	243274	244095	245088	

**Parts for TXT/HXT 305A, 405A and 505B
Straight-Bore and Tapered-Bushed Speed Reducers**

Ref.	Name of Part	No. Req'd	TXT305A HXT305A	TXT405A HXT405A	TXT505A HXT505A	
	Key, Bushing to Shaft ③	2-1/8" Bore	1	-----	244109	-----
		2-3/16" Bore	1	243276	244111	245090
		2-1/4" Bore	1	-----	244113	245092
		2-7/16" Bore	1	-----	244115	245094
		2-1/2" Bore	1	-----	-----	245099
		2-11/16" Bore	1	-----	-----	245110
		2-15/16" Bore	1	-----	-----	245112
86③	Bushing Screw ③	6	411407	411408	411435	
88	Lock Washer ③	6	419011	419011	419012	
90	Key, Bushing to Shaft ③	1-5/16" Bore	1	443264		
		1-3/8" Bore	1	443264		
		1-7/16" Bore	1	443265	443254	
		1-1/2" Bore	1	443265	443254	
		1-5/8" Bore	1	443265	443254	
		1-11/16" Bore	1	443266	443254	
		1-3/4" Bore	1	432666	443254	
		1-7/8" Bore	1	443267	443255	443251
		1-15/16" Bore	1	443269	443255	443251
		2" Bore	1	443268	443258	443251
		2-1/8" Bore	1		443259	
		2-3/16" Bore	1	443270	443260	443251
		2-1/4" Bore	1		443261	443251
		2-7/16" Bore	1			443243
		2-1/2" Bore	1			443244
2-11/16" Bore	1			443245		
2-15/16" Bore	1			443250		
①③ ⑨⑩	Key, Bushing to Output Hub ③	1	443262	443257	443202	
				443256		
	Torque-Arm Assembly ②	1	243097	245097	245097	
94	Rod End ③⑩	1	A73087	A73146	A73146	
96	Hex Nut ③⑩	1	407095	A73264	A73264	
98	Turbuckle ③⑩	1	A73089	A73147	A73147	
100	Extension ③⑩	1	A73088	A73148	A73148	
102	LH Hex Nut ③⑩	1	407244	245247	245247	
104	Fulcrum ③	1	243249	246249	246249	
106	Fulcrum Screw ③	1		032018016EJ		
110	Hex Nut ③	1	407093	407093	407093	
	Adapter Assembly ②	1	259153	259154	259155	
112	RH Adapter Plate ③	1	243242P	244244P	245242P	
114	LH Adapter Plate ③	1	243241P	244243P	245241P	
116	Adapter Bushing ③	1	243243	245243	245243	
118	Adapter Bolt ③	1	411437	411460	411460	
120	Lock Washer ③	1	419012	419013	419013	
122	Hex Nut ③	1	407089	407091	407091	
124	Motor Adapter	1	253172	254222	255226	
126	Adapter Screw	⑩	417090	417120	417120	
128	Lock Washer	⑩	419046	419047	419047	
130③	Input Shaft with Pinion	1	253171	254231	255222	

Notes:

- ① Not shown on drawing
- ② Includes part as follows: housing assembly includes a two-piece housing; bushing assembly includes 2 bushings
- ③ Makes up assembly under which it is listed
- ④ Washer is used on housing bolts at dowel pin locations
- ⑤ Straight-Bore only
- ⑥ Tapered-Bushed only
- ⑦ 10 required on 305A; 12 required on 405A and 505A.
- ⑧ Recommended spare parts
- ⑨ On size 305A for 1-15/16" through 1-3/4" bores; on size 405A for 1-7/16" through 1-7/8" bores; on size 505A for 1-7/8" through 2-1/4" bores
- ⑩ On size 405A for 1-15/16" and 2" bores
- ⑪ 4 required on HXT305A and HXT505A
- ⑫ Zinc plated as of 2016
- ⑬ Kit contains shims for the entire unit

Parts for TXT/HXT 6 and 7 Straight-Bore and Tapered-Bushed Speed Reducers

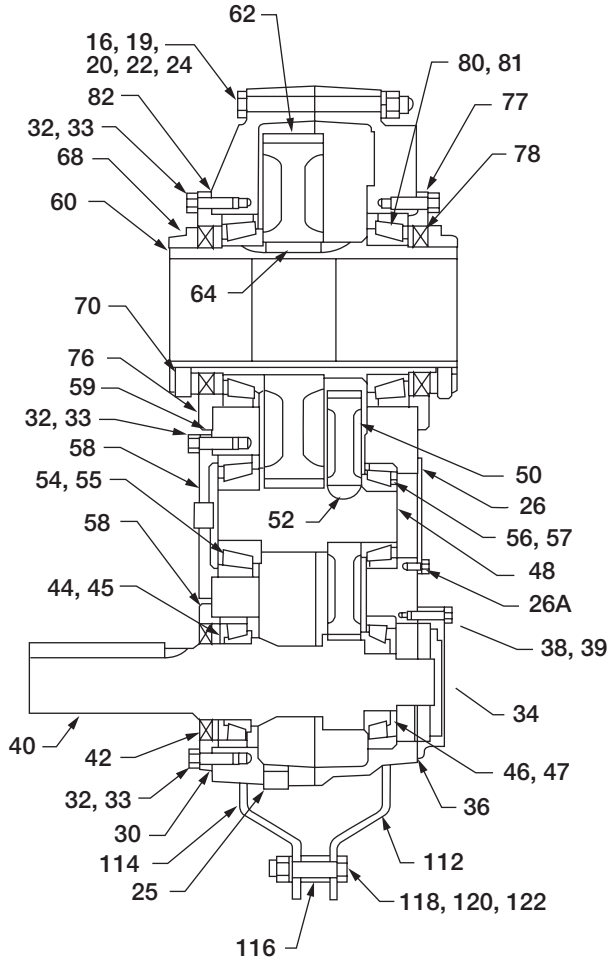

STRAIGHT BORE

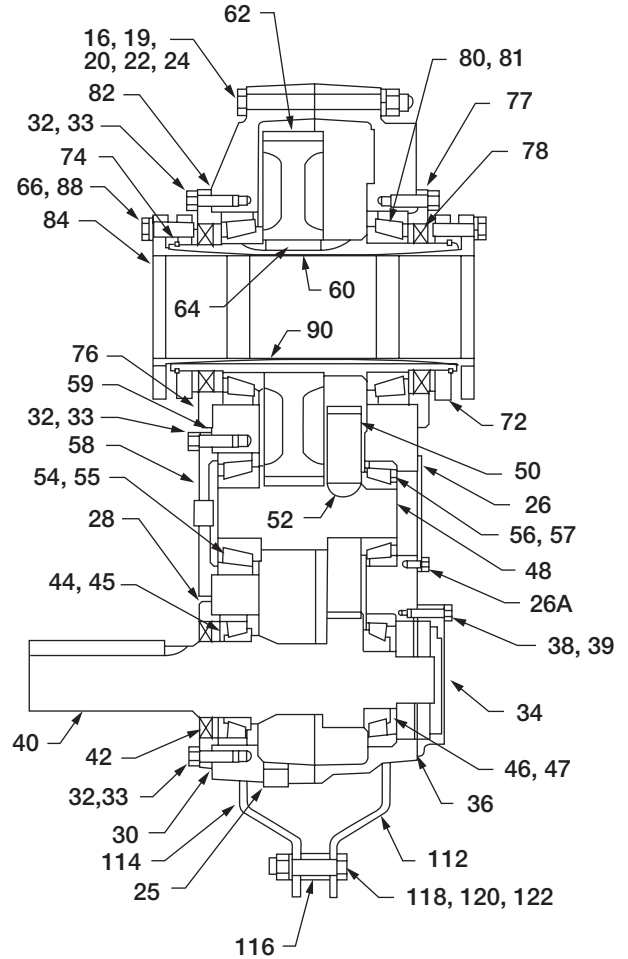

TAPER BUSHED

Note: The two digit numbers are for reference only. Order parts by the six digit number in the parts list. Each six digit number is a complete identification of the part or assembly.

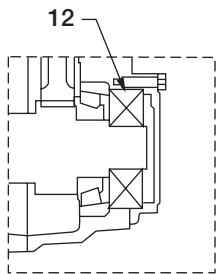

BACKSTOP ASSEMBLY

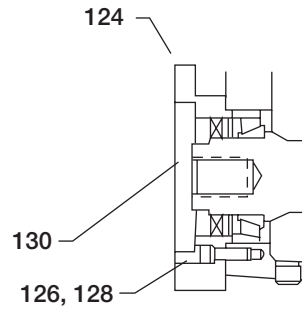

HYDROIL INPUT

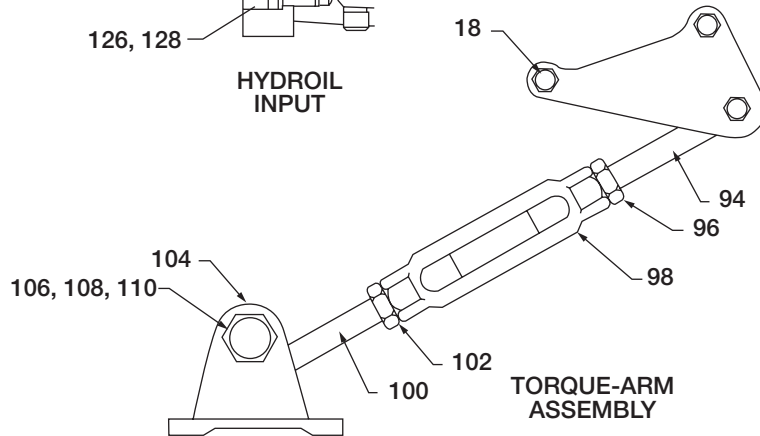

TORQUE-ARM ASSEMBLY

**Parts for TXT/HXT 6 and 7
Straight-Bore and Tapered-Bushed Speed Reducers**

Ref.	Name of Part	No. Req'd	TXT6 HXT6	TXT7 HXT7	
12	Backstop Assembly	1	246092	247260	
	Housing ②	1	246170	247180	
①	Air Vent	1	904287	390061	
16	Housing Bolt	6	411466	411498	
18	Adapter Housing	2	411468	411499	
19	Washer	2	419096	419082	
20	Lock Washer	8	419013	034017020AB	
22	Hex Nut	8	407091	407095	
24	Dowel Pin	2	420112	420128	
①	Pipe Plug	2	430033	430035	
25	Magnetic Plug	1	430062	430064	
26	Countershaft Bearing Cover (Backstop Side)	1	246015	247011	
26A	Countershaft Cover Screws	6	411394	411394	
	Countershaft Cover Washers	6	419009	419009	
28	Input Shaft Seal Carrier	1	246184	247320	
30 ③	Input Shaft Bearing Shim Pack	2	391164	390420	
32	Carrier / Cover Screws	⑦	032018010CJ	411433	
33	Lock Washer	⑦	419009	419009	
34	Backstop Cover	1	246221	247221	
38	Backstop Cover Screw	6	411404	411402	
39	Lock Washer	6	419009	419009	
40 ③	Input Shaft with Pinion	9:1 Ratio	1	246481	247479
		15:1 Ratio	1	246290	247370
		25:1 Ratio	1	246291	247371
41	Input Shaft Key	1	443113	443127	
44	Input Shaft Bearing	Cone	1	402196	402150
45 ③	(Input Side)	Cup	1	403091	403106
46 ③	Input Shaft Bearing	Cone	1	402197	402088
47 ③	(Backstop Side)	Cup	1	403091	403047
	Countershaft Assembly ②	9:1 Ratio	1	392140	392141
		15:1 Ratio	1	391171	391196
		25:1 Ratio	1	391186	391197
48	Countershaft with Pinion ③	1	246294	247002	
	First Reduction Gear ③	9:1 Ratio	1	246482	247478
		15:1 Ratio	1	246292	247008
		25:1 Ratio	1	246293	247005
	Standard Gear Key ③	1	D8244	301193	
52 ③	Crescent Gear Key ③	1	245218	247218	
58	Countershaft Bearing Cover (Input Shaft)	1	246185	247194	
59 ③	Countershaft Bearing Shim Pack	2 ⑥	391165	390429	
	Output Hub Assembly ②	Straight	1	390988	390990
		Tapered	1	390935	390941
60 ③	Output Hub ③	Straight	1	246338	247338
		Tapered	1	246269	272137
62 ③	Output Gear ③	1	246295	247215	
64 ③	Output Gear Key ③	2	245217	245217	
68	Output Hub Collar	2	246309	247309	
70	Collar Screw	4	400154	400190	
72	Bushing Backup Plate	2	246270	272138	
74	Retaining Ring	2	421055	421099	
76	Output Hub Seal Carrier (Input Side)	1	246187	247315	
77	Output Hub Seal Carrier (Backstop Side)	1	246186	247315	
②	Seal Kit ②	1	246340	347345	
36 ③	Backstop Cover Gasket ③	1	246220	246220	
42 ③	Input Shaft Seal ③	1	242210	242210	
78 ③	Output Hub Seal ③	2	905286	247310	
① ③	Gasket Eliminator Tube	1	415115-80-H		
②	Bearing Kit	1	335368	392353	
44 ③ ③	Input Shaft Bearing	Cone	1	402196	402150
45 ③ ③	(Input Side)	Cup	1	403091	403106
46 ③ ③	Input Shaft Bearing	Cone	1	402197	402088
47 ③ ③	(Backstop Side)	Cup	1	403091	403047
52 ③ ③	Countershaft Bearing	Cone	1	402054	402256
54 ③ ③	(Input Side)	Cup	1	403159	403053
56 ③ ③	Countershaft Bearing	Cone	1	402052	402256
57 ③ ③	(Backstop Side)	Cup	1	403142	403053
80 ③ ③	Output Hub	Cone	2	402050	402058
81 ③ ③	Bearing	Cup	2	403140	403111

**Parts for TXT/HXT 6 and 7
Straight-Bore and Tapered-Bushed Speed Reducers**

Ref.	Name of Part	No. Req'd	TXT6 HXT6	TXT7 HXT7	
30 59 ③ 82	Complete Shim Kit	1	246166	247138	
84 ③ ⑤	Tapered-Bore Bushing Assembly ①	2-3/16" Bore	1	246261	-----
		2-1/4" Bore	1	246262	-----
		2-7/16" Bore	1	246263	272125
		2-1/2" Bore	1	246264	272149
		2-11/16" Bore	1	246265	272147
		2-13/16" Bore	1	-----	272130
		2-7/8" Bore	1	246266	272131
		2-15/16" Bore	1	246267	272132
		3" Bore	1	246283	272133
		3-3/16" Bore	1	-----	272134
	3-7/16" Bore	1	246268	272135	
	3-15/16" Bore	1	-----	272136	
86 ⑤	Bushing Screw ③	6	411435	411456	
88 ⑤	Lock Washer ③	6	419012	419013	
90	Key, Bushing To Shaft ③	2-3/16" Bore	1	443211	-----
		2-1/4" Bore	1	443211	-----
		2-7/16" Bore	1	443214	443248
		2-1/2" Bore	1	443214	443248
		2-11/16" Bore	1	443238	443248
		2-13/16" Bore	1	-----	443199
		2-7/8" Bore	1	443236	443199
		2-15/16" Bore	1	443237	431199
		3" Bore	1	443252	443216
		3-3/16" Bore	1	-----	443235
	3-7/16" Bore	1	443213	443217	
	3-15/16" Bore	1	-----	443218	
① ③ ③	Key, Bushing To Output	2-1/16" Bore - 2-1/4" Bore	1	443212	-----
		2-7/16" Bore - 3" Bore	1	-----	443198
	Torque-Arm Assembly ②	1	246097	247098	
94 ⑥	Rod End ③	1	A73146	A73269	
96 ⑥	RH Nut ③	1	A73264	A73268	
98 ⑥	Turnbuckle ③	1	A73147	A73267	
100 ⑥	Extension ③	1	A73148	A73265	
102 ⑥	LH Nut ③	1	A73263	A73266	
104	Fulcrum ③	1	247248	247248	
106	Fulcrum Screw ③	1	411489	411489	
108	Lock Washer ③	1	034017018AB	034017018AB	
110	Hex Nut ③	1	407093	407093	
	Adapter Assembly ②	1	259156	259157	
112	RH Adapter Plate ③	1	246242P	247242P	
114	LH Adapter Plate ③	1	245241P	247241P	
116	Adapter Bushing ③	1	245243	247244	
118	Adapter Bolt ③	1	411460	411489	
120	Lock Washer ③	1	419013	034017018AB	
122	Hex Nut ③	1	407091	419014	
124	Motor Adapter	1	246465	247464	
126	Adapter Screw	6	417108	417141	
128	Lock Washer	6	419013	034017018AB	
130 ③	Input Shaft with Pinion	15:1 Ratio	1	246230	247463
		255:1 Ratio	1	246286	247462

Notes:

- ① Not shown on drawing
- ② Includes parts listed immediately below
Housing assembly includes a two-piece housing
Bushing assembly includes 2 bushings
- ③ Makes up assembly under which it is listed
- ④ Straight-Bore only
- ⑤ Tapered-Bushed only
- ⑥ Zinc plated as of 2016
- ⑦ 24 required on TXT6; 28 required on TXT7
- ⑧ Recommended spare parts
- ⑨ Key was changed from crescent shaped to standard key in April, 2006
For original HXT/TXT6 countershaft, use 245218; for current countershaft, use D8244
For original HXT/TXT7 countershaft, use 247218; for current countershaft, use 301193

Parts for TXT/HXT 605 and 705 Straight-Bore and Tapered-Bushed Speed Reducers

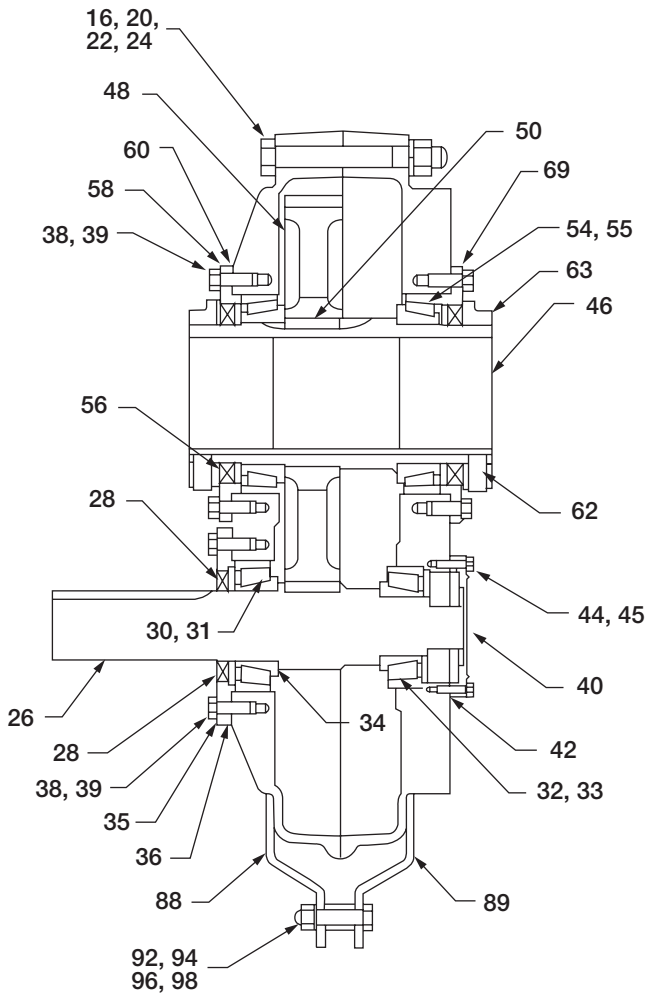

STRAIGHT BORE

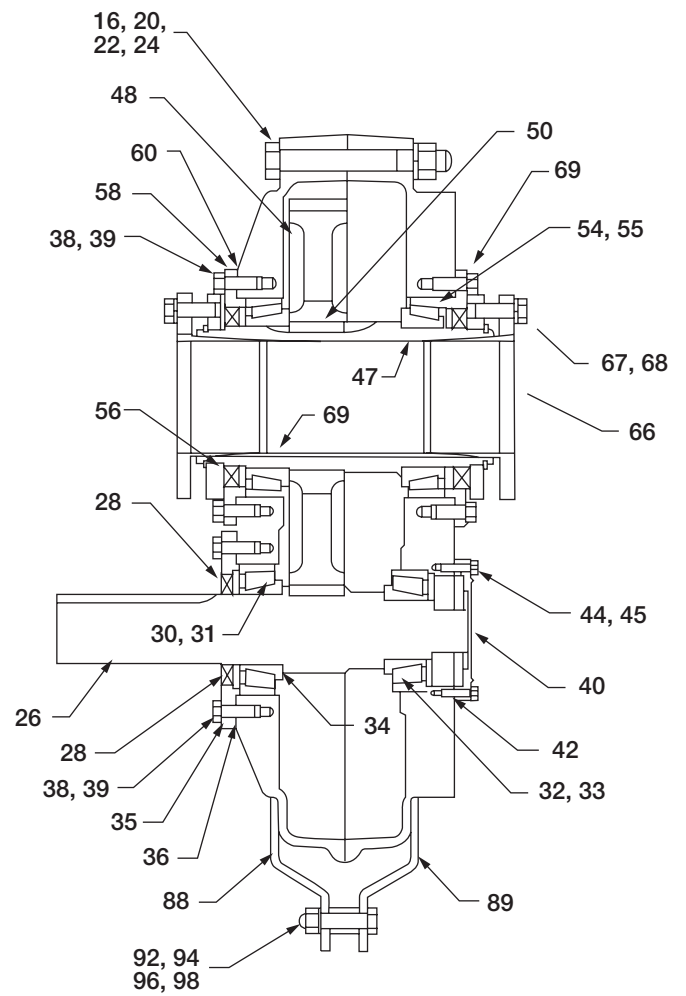

TAPER BUSHED

Note: The two digit numbers are for reference only. Order parts by the six digit number in the parts list. Each six digit number is a complete identification of the part or assembly.

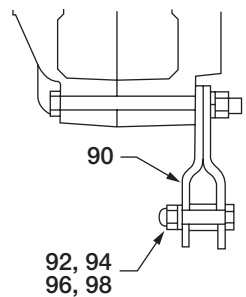

ADAPTER PLATE ASSEMBLY (TXT605 ONLY)

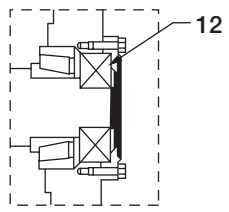

BACKSTOP ASSEMBLY

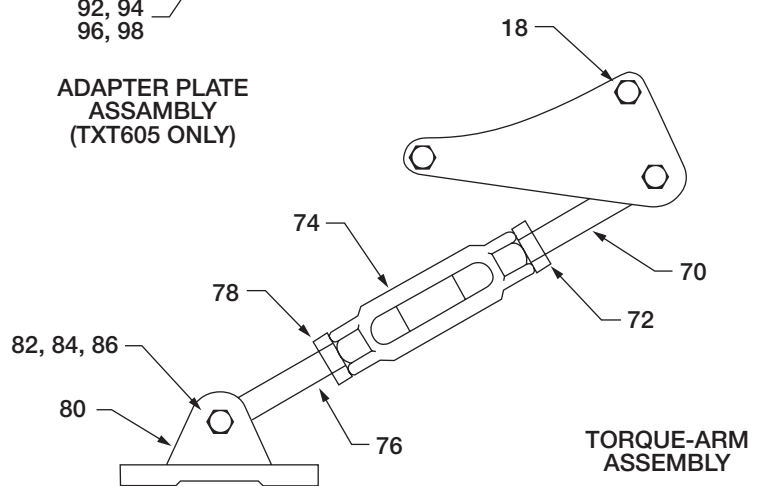

TORQUE-ARM ASSEMBLY

**Parts for TXT/HXT 605 and 705 Straight-Bore
and Tapered-Bushed Speed Reducers**

Ref.	Name of Part	No. Req'd	TXT605	TXT705	
12	Backstop Assembly	1	246092	247260	
	Housing ②	1	246174	247184	
①	Air Vent	1	904287	390061	
16	Housing Bolt	6	411466	411498	
18	Adapter Housing Bolt	2	411468	411499	
①	Washer	2	419096	419082	
20	Lock Washer	8	419013	034017020AB	
22	Hex Nut	8	407091	407095	
24	Dowel Pin	2	420112	420128	
①	Pipe Plug	2	430033	430035	
①	Magnetic Plug	1	430062	430064	
26 ③	Input Shaft with Pinion	1	256028	257044	
①	Input Shaft Key	1	443113	443127	
34 ③	Input Bearing Spacer	1	256030	-----	
35	Input Shaft Seal Carrier	1	246184	257045	
38	Carrier Screws	⑥	032018010CJ	411433	
39	Lock Washer	⑥	419011	419012	
40	Backstop Cover	1	246221	247221	
44	Backstop Cover Screw	6	411404	411402	
45	Lock Washer	6	419009	419009	
	Output Hub Assembly ②	Straight	1	390988	390990
		Tapered	1	390935	390941
46 ③	Output Hub	Straight	1	246338	247338
47 ③		Tapered	1	246269	272137
48 ③	Output Gear	1	246295	247215	
50 ③	Output Gear Key	2	245217	245217	
①⑥	O/P Hub Key	Max Bore	1	246343	247263
58	Output Hub Seal Carrier (Input Side)	1	246187	247315	
59	Output Hub Seal Carrier (Backstop Side)	1	246186	247315	
62	Collar Screw ⑤	4	400154	400190	
63	Output Hub Collar ⑤	2	243309	247309	
64	Bushing Backup Plate ⑥	2	246270	272138	
65	Retaining Ring ⑥	2	421055	421099	
⑨	Seal Kit	1	272705	247221	
42	Backstop Cover Gasket ④	1	246220	246220	
28 ③③	Input Shaft Seal	1	256032	242113	
56 ③③	Output Shaft Seal	2	905286	247310	
①	RTV Sealant, Tube	1	415112-80-H	415112-80-H	
②	Bearing Kit	1	392352	392354	
30 ③③	Input Shaft Bearing	Cone	1	402053	402057
31 ③		(Input Side)	Cup	1	403106
32 ③	Input Shaft Bearing	Cone	1	402123	402078
33 ③		(Backstop Side)	Cup	1	403009
54 ③	Output Hub	Cone	2	402050	402058
55 ③	Bearing	Cup	2	403140	403111
36 60 ③	Complete Shim Kit	1	241266	240121	

**Parts for TXT/HXT 605 and 705 Straight-Bore
and Tapered-Bushed Speed Reducers**

Ref.	Name of Part	No. Req'd	TXT605	TXT705	
66 ②⑥	Bushing Assembly	2-3/16" Bore	1	246261	-----
		2-1/4" Bore	1	246262	-----
		2-7/16" Bore	1	246263	272125
		2-1/2" Bore	1	246264	272149
		2-11/16" Bore	1	246265	272147
		2-13/16" Bore	1	-----	272130
		2-7/8" Bore	1	246266	272131
		2-15/16" Bore	1	246267	272132
		3" Bore	1	246283	272133
		3-3/16" Bore	1	-----	272134
		3-7/16" Bore	1	246268	272135
3-15/16" Bore	1	-----	272136		
67 ③	Bushing Screw ④	6	411435	411456	
68 ③	Lock Washer ④	6	419012	419013	
69 ⑥	Key, Bushing to Shaft ③	2-3/16" Bore	1	443211	-----
		2-1/4" Bore	1	443211	-----
		2-7/16" Bore	1	443214	44248
		2-1/2" Bore	1	443214	443248
		2-11/16" Bore	1	443238	443248
		2-13/16" Bore	1	-----	443199
		2-7/8" Bore	1	443236	443199
		2-15/16" Bore	1	443237	443199
		3" Bore	1	443252	443216
		3-3/16" Bore	1	-----	443235
		3-7/16" Bore	1	443213	443217
3-15/16" Bore	1	-----	443218		
①	Key, Bushing	2-15/16" - 2-1/2" Bore	1	443212	-----
③	Output Hub	2-7/16" - 3" Bore	1	-----	443198
	Torque-Arm Assembly ②	1	246097	247098	
70 ③④	Rod End	1	A73146	A73269	
72 ③④	Hex Nut ③	1	A73264	A73268	
74 ③④	Tumbuckle ③	1	A73147	A73267	
76 ③④	Extension ③	1	A73148	A73265	
78 ③④	LH Hex Nut ③	1	A73263	A73266	
80	Fulcrum ③	1	247248	247248	
82	Fulcrum Screw ③	1	411489	411489	
84	Lock Washer ③	1	034017018AB	034017018AB	
86	Hex Nut ③	1	409093	407093	
	Adapter Assembly ②	1	259159	259157	
88	RH Adapter Plate ③	1	-----	247242P	
89	LH Adapter Plate ③	1	-----	247241P	
90	Adapter Plate Assembly ③	1	256096P	-----	
92	Adapter Bushing ③	1	245243	247244	
94	Adapter Bait ③	1	411460	411488	
96	Lock Washer ③	1	419013	034017018AB	
98	Hex Nut ③	1	407091	407093	

Notes:

- ① Not shown on drawing
- ② Includes parts listed immediately below
Housing assembly includes a two-piece housing
Bushing assembly includes 2 bushings
- ③ Makes up assembly under which it is listed
- ④ Zinc plated as of 2016
- ⑤ Straight-Bore only
- ⑥ Tapered-Bushed only
- ⑦ See last paragraph under "ordering parts"
- ⑧ 18 required on TXT605; 22 required on TXT705
- ⑨ Recommended spare parts

Oil Viscosity Equivalency Chart

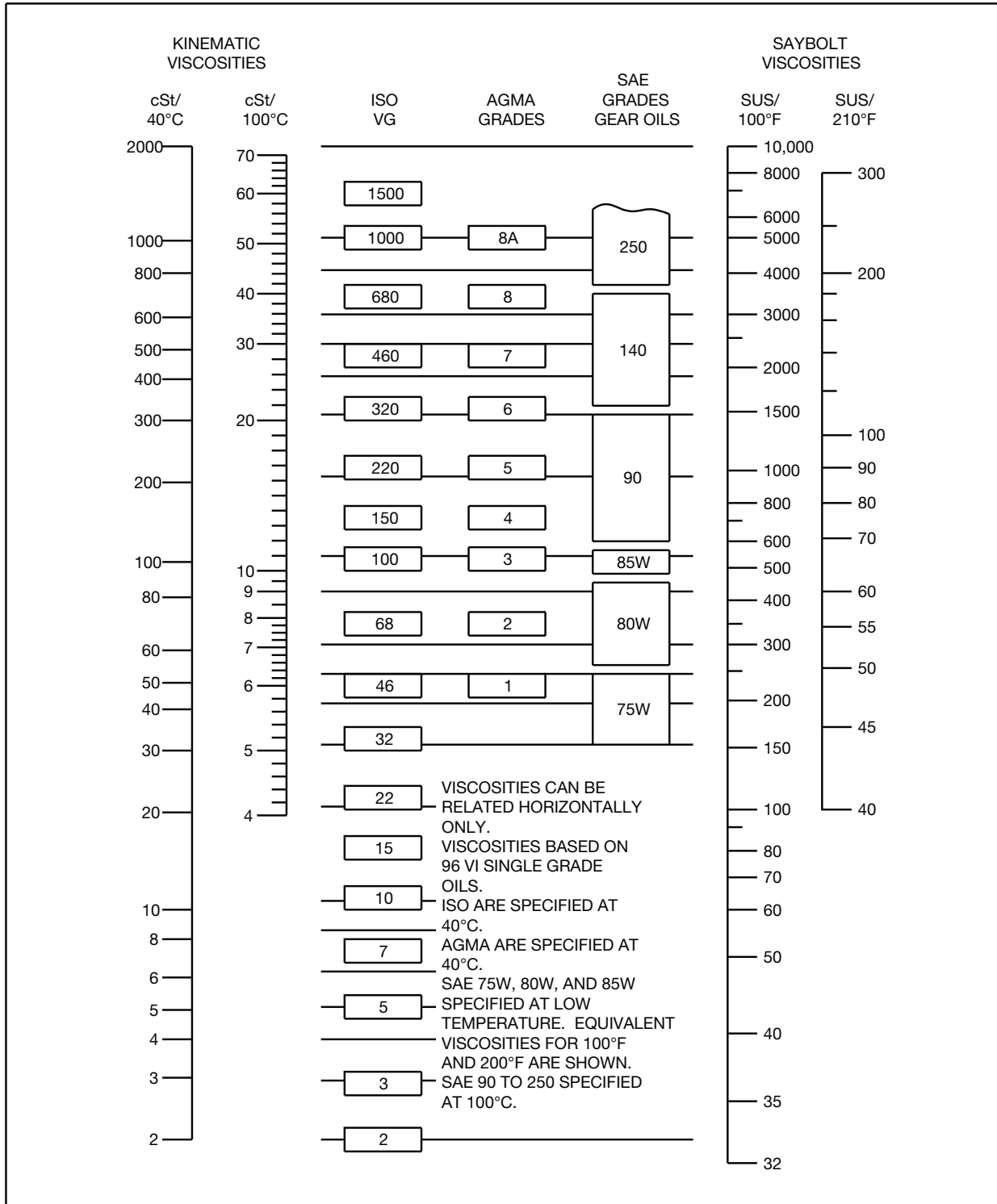

Dodge Industrial, Inc.
 1061 Holland Road
 Simpsonville, SC 29681
 +1 864 297 4800

